

Standard Trench Box Information Sheet

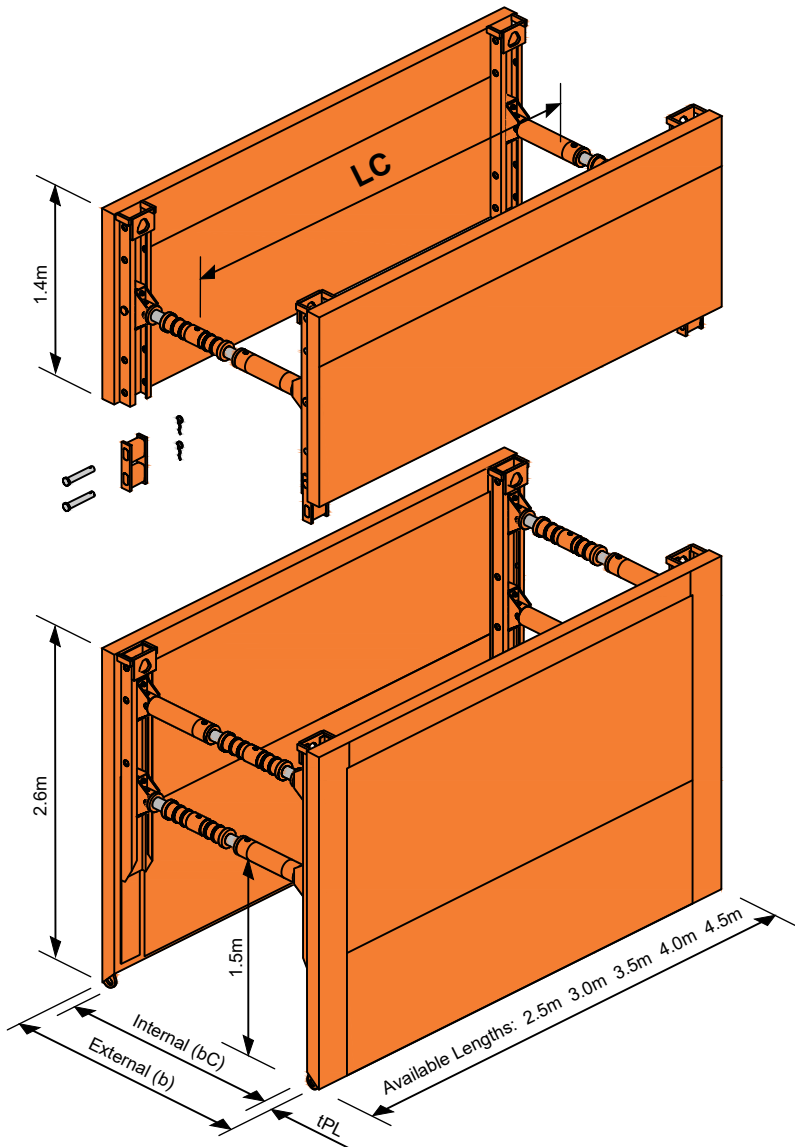

Designed for deeper trenches and poor ground conditions, the Standard Trench Box range offers reliable trench support.

With three adjustable spindle types, the Standard Trench box system can achieve **trench widths of 0.85 - 4.48m** using a combination of extension pieces. See overleaf for detailed spindle information.

Box Length L m	Clearance LC m	Thickness tPL mm	Trench Width [b] v Permissible Earth Pressure [kN/m ²]			
			<3.0m	<3.5m	<4.0m	<4.5m
2.5	2.1	107	57.0	51.7	42.7	33.6
3.0	2.6		47.5	43.0	35.6	28.0
3.5	3.1		40.7	36.9	30.5	24.0
4.0	3.6	127	35.6	32.2	26.7	21.0
4.5	4.1		33.7	30.5	25.2	19.8

A forklift/machine must be provided to off load the kit from the delivery vehicle.
Alternatively SEL can deliver the equipment on a HIAB vehicle by prior arrangement.

Box Length L m	Panel Height H m	Maximum Weight per complete box [kg]								
		Mini-0.0	Midi-0.0	Maxi-0.0	Maxi-0.5	Maxi-1.0	Maxi-1.5	Maxi-2.0	Maxi-2.5	Maxi-3.0
2.5	2.6 Base	1680	1708	1741	1820	1899	1978	2058	2137	2216
	1.4 Top	990	1003	1020	1060	1100	1139	1179	1218	1258
3.0	2.6 Base	1935	1963	1996	2075	2154	2233	2313	2392	2471
	1.4 Top	1134	1148	1165	1205	1245	1284	1324	1363	1403
3.5	2.6 Base	2180	2208	2241	2320	2399	2478	2558	2637	2716
	1.4 Top	1280	1293	1310	1350	1390	1429	1469	1508	1548
4.0	2.6 Base	2420	2448	2481	2560	2639	2718	2798	2877	2956
	1.4 Top	1425	1438	1455	1495	1535	1574	1614	1653	1693
4.5	2.6 Base	2950	2978	3011	3090	3169	3248	3328	3407	3486
	1.4 Top	1810	1823	1840	1880	1920	1959	1999	2038	2058

Standard Trench Box Information Sheet

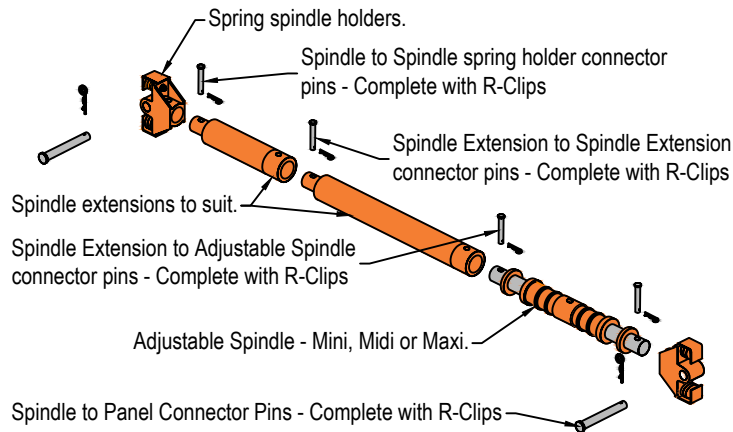

Box Spindle Type	Internal Width	External Width	Each spindle contains a spindle adjuster plus the following spindle extensions			Weight
	bC	b	0.5m	1.0m	2.0m	G
	(m)	(m)				(kg)
Mini-0.0	0.65 - 0.75	0.85 - 0.95	0	0	0	50.0
Mini-0.5	1.15 - 1.25	1.35 - 1.45	1	0	0	69.8
Mini-1.0	1.65 - 1.75	1.85 - 1.95	0	1	0	89.6
Mini-1.5	2.15 - 2.25	2.35 - 2.45	1	1	0	109.4
Mini-2.0	2.65 - 2.75	2.85 - 2.95	0	0	1	129.2
Mini-2.5	3.15 - 3.25	3.35 - 3.45	1	0	1	149.0
Mini-3.0	3.65 - 3.75	3.85 - 3.95	0	1	1	168.8
Midi-0.0	0.83 - 1.02	1.03 - 1.22	0	0	0	57.0
Midi-0.5	1.33 - 1.52	1.53 - 1.72	1	0	0	76.8
Midi-1.0	1.83 - 2.02	2.03 - 2.22	0	1	0	96.6
Midi-1.5	2.33 - 2.52	2.53 - 2.72	1	1	0	116.4
Midi-2.0	2.83 - 3.02	3.03 - 3.22	0	0	1	136.2
Midi-2.5	3.33 - 3.52	3.53 - 3.72	1	0	1	156.0
Midi-3.0	3.83 - 4.02	4.03 - 4.22	0	1	1	175.8
Maxi-0.0	0.98 - 1.26	1.20 - 1.48	0	0	0	65.0
Maxi-0.5	1.48 - 1.76	1.70 - 1.98	1	0	0	84.8
Maxi-1.0	1.98 - 2.26	2.20 - 2.48	0	1	0	104.6
Maxi-1.5	2.48 - 2.76	2.70 - 2.98	1	1	0	124.4
Maxi-2.0	2.98 - 3.26	3.20 - 3.48	0	0	1	144.2
Maxi-2.5	3.48 - 3.76	3.70 - 3.98	1	0	1	164.0
Maxi-3.0	3.98 - 4.26	4.20 - 4.48	0	1	1	183.8

For 4.50m Long boxes, add 40mm to the 'External Width' column.